

Thank you for purchasing the UWAY XtendIR universal infrared flash extender product. You can now enjoy many benefits of using the XtendIR with popular infrared game cameras to improve flash range and image quality. This product is designed to operate in synchronicity with your infrared camera in both photo and movie modes. This product utilizes high quality and high output LEDs designed to provide maximum viewing range. Optimal results will be obtained when using the guidelines covered in this manual.

Uway Flash Extender User's Manual (XtendIR-B)

SPECIFICATIONS

- 110 High Output LED Array
- Main Enhancement LED Bank (60 Leds)
- Wide Angle Illumination Bank (20 Leds)
- Distance Illumination Bank (30 Leds)
- Adjustable illumination from 30 to 50+ feet (standalone)
- 3 foot Infrared Sensor Cable connects to ALL IR cameras
- Functions in Photo and Movie Modes
- Uses 4 "D" NiMH or NiCd or Li Batteries Internal
- 6 Volt External Battery port
- Innovative Curved rear mounts provide both mounting and security using strap, bungee and python lock
- Adjust angles up and down for easy camera alignment
- Brown Anti-Reflective Color Surface
- Patent Pending

KIT INCLUDES

- XtendIR Main Unit
- Sensor Cable
- Cinch Strap
- Users Manual

POWER

“D” Batteries

The XtendIR requires 4 type “D”Li batteries or NiMH or NiCd rechargeable batteries. The performance and battery lifetime (per charge) will depend on the capacities (MAH) of the rechargeable cells. **Alkaline batteries will cause low performance, it's strongly recommended not to use them with XtendIR-B.**

Install the batteries according to the instructions in the XtendIR case. Proper polarity must be followed to operate the unit.

6V External power

The XtendIR provides a port for an external 6V battery. External battery cables and power station are sold separately. When the external power port is used, the internal batteries are shunted. This means that the unit will operate from either internal or external but not a combination. Optimal performance should be achieved with a 6V SLA (Sealed Lead Acid) type battery.

FEATURES (see diagram A)

- Day/Night Light Sensor
- LED Bank 1 Main Enhancement Bank 60 LEDS
- LED Bank 2 Wide-Angle Bank 20 LEDS
- LED Bank 3 Distance Bank 30 LEDS
- Sensor Plug Port

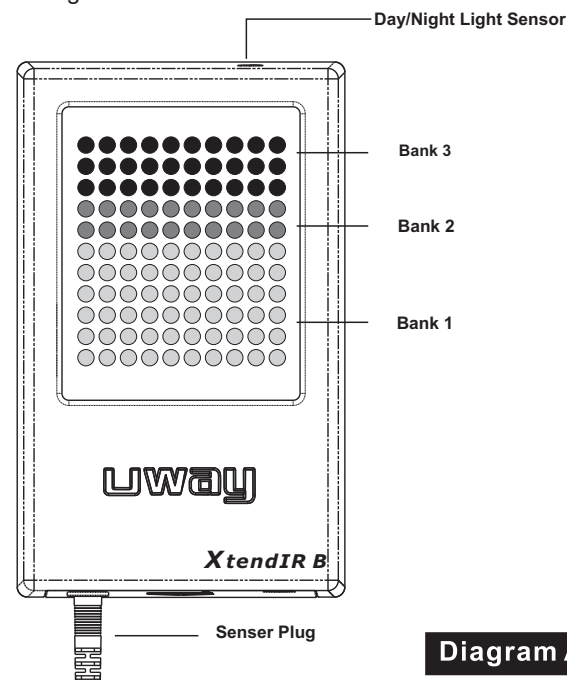

Diagram A

Day/Night Sensor:

This sensor should not be blocked during operation. It is used to determine the amount of ambient light available and to disable the unit when it is sufficiently light. The LUX on this sensor is designed to make the XtendIR more sensitive to daylight by approximately 30 minutes than the average camera. This design was employed to avoid whiteout or washout during transition lighting periods such as early morning and late evening. During these time periods the camera LEDs should be sufficient and the XtendIR will begin to operate when ambient conditions are darker.

LED Bank 1:

This bank is the default bank of LEDs and considered the “enhancement bank”. It is composed of 60 LEDs which provide standard image enhancement. This bank is activated by flipping the POWER (white) switch to the ON position.

Note: the POWER (white) switch is the main power control switch. When in the OFF position the device is powered OFF (regardless of bank 2 and 3 switches).

LED Bank 2:

This bank is considered to be the “wide angle bank” and is also composed of 20 LEDs. The purpose of this bank is to not only enhance the center of the image but push extra flash into the periphery of the image. Activate this bank by flipping the BANK 2 switch to the ON position.

LED Bank 3:

This bank is considered to be the “distance illumination bank”. It is composed of 30 LEDs with a narrow, more focused range. The effect is to push more illumination into the center of the image. Activate this bank by flipping the BANK 3 switch to the ON position.

A note on battery consumption:

Using banks 2 and 3 will increase the power consumption of the device. In order to gain longer battery life, use fewer banks when they are sufficient.

For camera in video mode, when multiple banks are needed (especially three banks), it is recommended setting the video length to no more than 20 seconds.

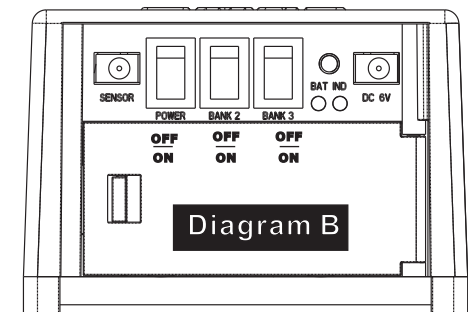

OPERATION

Open the bottom cover to reveal switch panel & battery compartment. (See diagram B).

- Sensor Port
- POWER Switch
- BANK 2 Switch
- BANK 3 Switch
- Battery Indicator Button
- Battery Indicator LEDs 1 and 2
- 6V DC External Power Port
- Battery Compartment Door

To operate the XtendIR, provide power using either internal “D” cells or external 6V power via external cable and battery. Select a combination of banks (2 and/or 3 or neither) to suit your illumination needs and battery conservation requirements, flip the POWER switch to ON. Slide the bottom cover door shut. See POWER section for more information on batteries.

Insert the Sensor arm into the sensor port gently but with firm pressure to ensure a good contact. Press until the cable slides in all the way.

Mount the XtendIR near the camera, attach the sensor arm cup (see diagram C) over the LED array of the camera.

The sensor cup should be placed as nearly directly over an LED on the camera as possible for optimal triggering. Use a square segment of Velcro on your camera or nearby to anchor the sensor arm in place. Bend the sensor cup in place over the LED array of the camera.

The XtendIR-B can operate in two modes as a flash extender and as a flash replacement:

Flash Extender

The XtendIR-B can function as a flash extender or as a flash replacement. To function as a flash extender follow the instructions above. Typically your camera would be a black flash camera in this mode of operation.

Flash replacement

The XtendIR-B can serve as a flash replacement for red flash IR cameras by blocking the existing array of your camera (leaving a hole for at least one LED to illuminate the sensor). Place an opaque material over your LED array. Punch a hole above one of the LEDs in the array. Mount the sensor as described above placing the sensor cup over the hole. When the camera's array fires the XtendIR-B will fire. This will enable the owner to convert an existing red flash (visible) IR camera to a black flash (invisible) IR camera.

MOUNTING

Optimal results can be achieved by mounting the XtendIR in the same plane

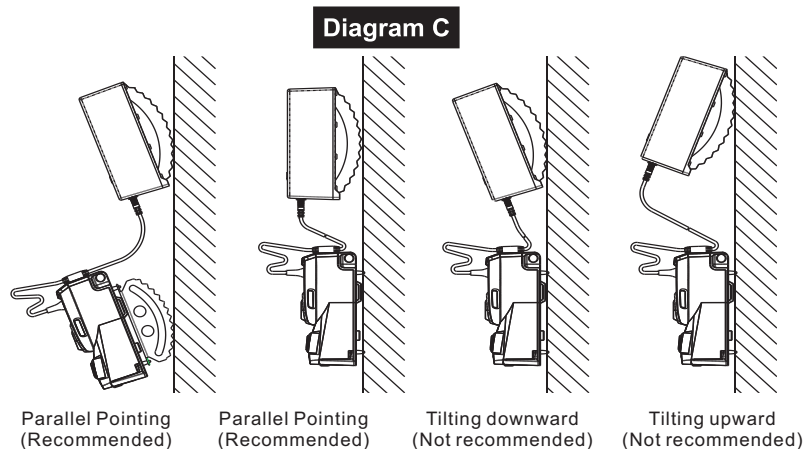

as the camera. This means they should be aimed as closely as possible in the same direction. Tests reveal that a parallel mounting will improve reflective illumination from the LEDs. (See Diagram C)

There are three ways to mount the XtendIR.

- A cinch strap
- A bungee cord
- A locking cable

The curved rear mounts allow for easy angle adjustments up and down when mounting the unit. A strap or bungee cord is enough to hold the unit in place while a locking cable is inserted to secure the unit.

TROUBLESHOOTING

Testing the Battery:

Turn off the POWER switch, then test the battery by pressing the Battery Indicator button. The two LEDs will indicate the current battery strength and level for the current power source (internal or external battery). Two lit battery indicator LEDs means High strength. One LED lit indicates that the battery is less than 10-15%. At this point, it is better to use one bank only or charge the batteries. No LEDs indicates battery is dead.

Note: When testing the battery using the Test Button (see Diagram B) the main LED Bank will light up. This places the batteries under a load to produce a more realistic battery level. In the dark this will also stand as a visual aid to let you know the unit is functioning. Releasing the Test Button, the main LED bank will be off in 2-3 seconds.

Photos or Videos are too bright:

One option is to use fewer banks on the XtendIR which will reduce the amount of light produced and reflected into the camera lens. Another option is to move the unit and camera farther away from the target subjects.

Poor Illumination:

Ensure that the XtendIR and the camera are aimed in parallel (in the same direction). This will improve the reception of the IR emissions from the XtendIR by the camera's lens. Poor illumination may also result from low battery level, check it according to the procedures stated in the earlier sections.

Unstable Illumination:

This may happen when the battery level is very low and multiple banks are turned on. You may observe the flickering of LEDs or banks. At this stage, just use the main LED bank or charge the batteries.

This may also happen when the camera is in long minute video mode and multiple banks are turned on, XtendIR is designed with a built-in self-protect mechanism against overheating. Shortening the video length will resolve this issue.

Limited Warranty

The unit purchased from our authorized dealer is warranted to be free from defects in material and workmanship for 1 year of the original purchase under normal use. Uway, will, at its option, repair or replace your product, with the same or comparable model free of charge (except you must pay for shipping charges set forth below) for a period of (1) one year from the date of original purchase in the event of a defect in materials or workmanship occurring during normal use. This warranty only extends to the original retail purchaser. Purchase receipt or other proof of date of original purchase is required before warranty performance. The warranty on any replacement product provided under this warranty shall be for the unexpired portion of the warranty period applicable to the original product.

This warranty extends solely to failures due to defects in materials or workmanship occurring during normal use. It does not cover normal wear of the product. This warranty is void if: the product housing has been removed, if the product's label, logo or serial number have been removed or if the product fails to function properly as a result of accident, misuse, abuse, neglect, mishandling, misapplication, non-compatible batteries, faulty installation, setup, adjustments, improper maintenance, alteration, maladjustment of controls, modification, power surges, service by anyone other than Uway or Uway authorized service center or acts beyond the manufacturer's or distributor's control.

Should your product prove defective during this warranty period, please contact Uway and follow the instructions. ***RMA number is required for all returns.**

Include \$11.95 for return shipping & insurance. (For U.S. customers only. Check or money order only, non-refundable). If the unit is out the warranty, the price for repairing or replacing may vary. Please allow 6-8 weeks for delivery. Customers out of U.S. pay different amount of shipping & insurance. We will send detailed information along with the RMA number.

Include with your product the RMA form and a copy of your dated cash register receipt or other proof of purchase.

***Please consult your dealer or us if you have any question or problem while you use the unit before you request a RMA number and send the unit back for repair. Some problem may easily be solved with help from our dealer or us.**



3120 Medlock Bridge Road, Suite H400

Norcross, GA, 30071 U.S.A.

1-770-582-0004 (TEL), 1-803-334-4505 (FAX)

support@uwayoutdoors.com [http:// www.uwayoutdoors.com](http://www.uwayoutdoors.com)

Made by Uway, your technology leader, "Leading the Way!"